

LMM-150 SERIES



Features

- Digital signal processor
- Auto trace white balance
- Automatic gain control
- 3.7mm pinhole lens
- Infrared acceptable



Dimensions

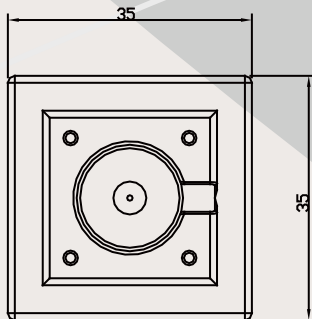
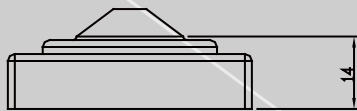

ITEMS	LMM-150 SERIES
SCANNING SYSTEM	2:1 Interlace
ELECTRONIC SHUTTER	Auto
GAIN CONTROL	Auto
BACK LIGHT COMPENSATION	Auto
WHITE BALANCE	Auto
S/N RATIO	More Than 48 dB
GAMMA	0.45
VIDEO OUTPUT	1 VP-P, 75 ohms
STORAGE/OPERATING TEMPERATURE	-30°C ~ +60°C / -10°C ~ +45°C
DIMENSIONS (L*W*H) mm	35×35×14
WEIGHT	180g

Model NO.	Image Sensor	Picture Elements H*V	TVL	Lens Type (mm)	Power Consumption	Sensitivity F:1.2	Chip
LMM-150ASE	1/3" SONY CCD	NTSC:512(H)×492(V) PAL:500(H)×582(V)	420	3.6/3.7mm	DC 12V /80mA	0.1 LUX	NEXT CHIP
LMM-150ASH	1/3" SONY Super HAD CCD	NTSC:512(H)×492(V) PAL:500(H)×582(V)	480	3.6/3.7mm	DC 12V /90mA	0.5 LUX	NEXT CHIP